

DRIVER: Wolfman
 EVENT: Spring Fling
 CLASS: Mod Sprint
 TRACK: Slideways Brownstown IL

Clay Hard Packed Loose Dirt
 Carpet Asphalt Concrete
 Flat Banked True Oval Tri-Oval
 Traction: High Medium Low

LEFT	FRONT SUSPENSION	RIGHT
0	CAMBER	-2
CASTOR		
<input type="checkbox"/> +10° <input type="checkbox"/> +5° <input type="checkbox"/> 0° <input checked="" type="checkbox"/> -5° <input type="checkbox"/> -10° <input type="checkbox"/> +10° <input type="checkbox"/> +5° <input checked="" type="checkbox"/> 0° <input type="checkbox"/> -5° <input type="checkbox"/> -10°		
ACKERMANN		
<input type="checkbox"/> OUTER <input checked="" type="checkbox"/> MIDDLE <input type="checkbox"/> INNER <input type="checkbox"/> INNER <input checked="" type="checkbox"/> MIDDLE <input type="checkbox"/> OUTER		
.062"	AXLE SHIMS	Full/.125"
OUTER CAMBER LINK LOCATION		
<input checked="" type="checkbox"/> OUTER <input type="checkbox"/> INNER <input type="checkbox"/> INNER <input checked="" type="checkbox"/> OUTER		
<input checked="" type="checkbox"/> 0° <input type="checkbox"/> ANGLED KINGPIN INCLINE <input type="checkbox"/> ANGLED <input checked="" type="checkbox"/> 0°		
.080"	CAMBER RATE SHIMS	.080"
SUSPENSION LOCATION		
<input checked="" type="checkbox"/> OUTER <input type="checkbox"/> MIDDLE <input type="checkbox"/> INNER <input type="checkbox"/> INNER <input type="checkbox"/> MIDDLE <input checked="" type="checkbox"/> OUTER		
KICK-UP: <input type="checkbox"/> 15° LO <input type="checkbox"/> 15° HIGH <input type="checkbox"/> 20° LO <input type="checkbox"/> 20° HIGH <input checked="" type="checkbox"/> 25° <input type="checkbox"/> 35°		
TOE: NONE SWAY BAR: <input type="checkbox"/> NONE <input checked="" type="checkbox"/> .063		

SHOCK LOCATION:
ON SUSP ARM:
 A B C

SHOCK LOCATION:
 A B C
 D E F

-SHADE IN MOUNTING LOCATIONS ON SUSPENSION ARMS, BEARING CARRIER AND SHOCK TOWER.

TIRES & TRACTION		
TIRE TYPE: <input type="checkbox"/> FOAM <input type="checkbox"/> STREET RUBBER <input type="checkbox"/> LOOSE		
COMPOUND	DIAMETER	INSERT
RF: <u>AKA Rebar SS</u>		<u>AKA RED</u>
LF: <u>"</u>		<u>"</u>
RR: <u>"</u>		<u>"</u>
LR: <u>"</u>		<u>"</u>
CLEANED WITH: <u>Water</u>		
TRACTION ADDITIVE: <u>FDJ Gold</u>		
NOTES: <u>Tires were slicks.</u>		
<u>CA Glue on outer 1/8 of RF tire to not traction roll.</u>		

SHOCKS			
COLLAR LENGTH		SHOCK LENGTH	
LEFT FRONT		RIGHT FRONT	
BODY LENGTH		BODY LENGTH	
<input type="checkbox"/> SHORT <input type="checkbox"/> MED <input checked="" type="checkbox"/> LONG		<input type="checkbox"/> SHORT <input type="checkbox"/> MED <input checked="" type="checkbox"/> LONG	
SHAFT LENGTH		SHAFT LENGTH	
<input type="checkbox"/> SHORT <input type="checkbox"/> MED <input checked="" type="checkbox"/> LONG		<input type="checkbox"/> SHORT <input type="checkbox"/> MED <input checked="" type="checkbox"/> LONG	
SPRING: <u>CW Yellow</u>		SPRING: <u>CW Red</u>	
OIL: <u>35 Assoc</u>		OIL: <u>35 Assoc</u>	
PISTON: <u>M</u>		PISTON: <u>M</u>	
LENGTH: <u>3.16</u>		LENGTH: <u>3.16</u>	
COLLAR: _____		COLLAR: _____	
LEFT REAR		RIGHT REAR	
BODY LENGTH		BODY LENGTH	
<input type="checkbox"/> SHORT <input type="checkbox"/> MED <input checked="" type="checkbox"/> LONG		<input type="checkbox"/> SHORT <input type="checkbox"/> MED <input checked="" type="checkbox"/> LONG	
SHAFT LENGTH		SHAFT LENGTH	
<input type="checkbox"/> SHORT <input type="checkbox"/> MED <input checked="" type="checkbox"/> LONG		<input type="checkbox"/> SHORT <input type="checkbox"/> MED <input checked="" type="checkbox"/> LONG	
SPRING: <u>CW Red</u>		SPRING: <u>CW Red</u>	
OIL: <u>35 Assoc</u>		OIL: <u>35 Assoc</u>	
PISTON: <u>M</u>		PISTON: <u>M</u>	
LENGTH: <u>3.22</u>		LENGTH: <u>3.22</u>	
COLLAR: _____		COLLAR: _____	

LEFT	REAR SUSPENSION	RIGHT
+4	CAMBER	-3.5
-6	TOE	+4
WHEEL SPACERS		
<input type="checkbox"/> .250" <input type="checkbox"/> .125" <input checked="" type="checkbox"/> NONE <input type="checkbox"/> NONE <input checked="" type="checkbox"/> .125" <input type="checkbox"/> .250"		
BEARING CARRIER SPACING		
RIGHT: <input type="checkbox"/> FWD <input type="checkbox"/> 1-OFF FWD <input type="checkbox"/> MIDDLE <input checked="" type="checkbox"/> 1-OFF REAR <input type="checkbox"/> REAR		
LEFT: <input type="checkbox"/> FWD <input type="checkbox"/> 1-OFF FWD <input type="checkbox"/> MIDDLE <input type="checkbox"/> 1-OFF REAR <input checked="" type="checkbox"/> REAR		
<input checked="" type="checkbox"/> LONG <input type="checkbox"/> SHORT INNER SUSP MOUNT <input type="checkbox"/> SHORT <input checked="" type="checkbox"/> LONG		
ANTI-SQUAT SHIMS		
<input checked="" type="checkbox"/> 3° <input type="checkbox"/> 1.5° <input type="checkbox"/> NONE <input type="checkbox"/> NONE <input type="checkbox"/> 1.5° <input checked="" type="checkbox"/> 3°		
ROLL CENTER SHIMS		
<input type="checkbox"/> .125" <input type="checkbox"/> .060" <input checked="" type="checkbox"/> NONE <input checked="" type="checkbox"/> NONE <input type="checkbox"/> .060" <input type="checkbox"/> .125"		
OUTER CAMBER LINK LOCATION		
<input checked="" type="checkbox"/> OUTER <input type="checkbox"/> INNER <input type="checkbox"/> INNER <input checked="" type="checkbox"/> OUTER		
BEARING CARRIER PIN HEIGHT		
<input type="checkbox"/> HIGH R.C. <input checked="" type="checkbox"/> LOW R.C. (NEAR AXLE) <input checked="" type="checkbox"/> LOW R.C. <input type="checkbox"/> HIGH R.C.		

SHOCK LOCATION: A B C D E

-SHADE IN MOUNTING LOCATIONS ON SUSPENSION ARMS, BEARING CARRIER AND SHOCK TOWER.

SHOCK LOCATION:
ON SUSP ARM:
 A B



RECEIVER
 AS SHOWN

SPEED CONTROL
 AS SHOWN
 By Receiver

TRANNY LOCATION:
 FORWARD
 REAR

ADDED WEIGHT:
 FRONT _____
 MIDDLE _____
 REAR _____

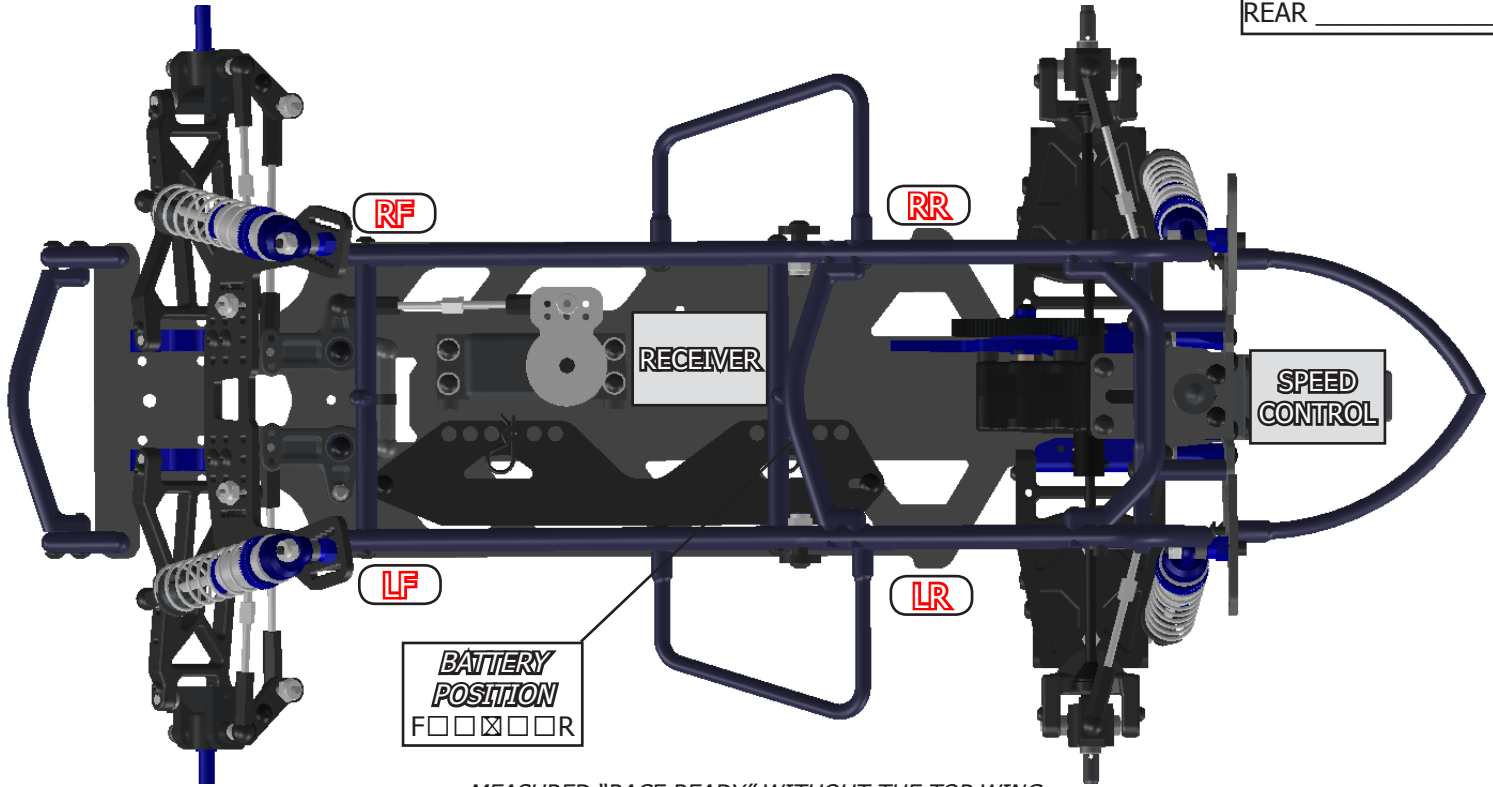

-MEASURED "RACE READY" WITHOUT THE TOP WING

<p>RIDE HEIGHTS BY LOCATION:</p> <p>LF: _____ RF: _____</p> <p>LR: _____ RR: _____</p> <p>MEASURED FROM: <input checked="" type="checkbox"/> TOP OF CHASSIS <input type="checkbox"/> BOTTOM OF CHASSIS</p>	<p>CORNER WEIGHTS:</p> <p>LF: _____ RF: _____</p> <p>LR: _____ RR: _____</p> <p>OVERALL: _____</p>	<p>MAX CHASSIS HEIGHT:</p> <p>LF: _____ RF: _____</p> <p>LR: _____ RR: _____</p> <p>MEASURED FROM: <input type="checkbox"/> TOP OF CHASSIS <input type="checkbox"/> BOTTOM OF CHASSIS</p>
<p>POWER SETTINGS</p> <p>MOTOR: 7.5</p> <p>AMP DRAW: _____</p> <p>TIMING: _____</p> <p>PINION: 27</p> <p>SPUR: 96</p> <p>SPEED CONTROL: Orion <input type="checkbox"/> "BLINKY" <input checked="" type="checkbox"/> OPEN</p> <p>SETTINGS: No Boost</p>	<p>AERO</p> <p>MAIN WING <input type="checkbox"/> 6X6 <input checked="" type="checkbox"/> 7X7</p> <p>FRONT WING <input type="checkbox"/> NONE <input type="checkbox"/> SMALL <input checked="" type="checkbox"/> LARGE</p> <p>HOOD TYPE <input type="checkbox"/> TRADITIONAL <input checked="" type="checkbox"/> SCOOP (HIGH DF)</p>	<p>MAIN WING LOCATION</p> <p style="text-align: right;"> 1 2 3 4 5 6 A ○○○○X○ B ○○○○○ C ○○○○○ D ○○○○○○ 1 2 3 4 5 6 7 </p> <p><input checked="" type="checkbox"/> LOW WING</p> <p><input type="checkbox"/> HIGH WING</p>
<p>BATTERY: _____</p> <p>MOTOR TEMP AFTER RUN: _____</p>		

NOTES: Car carries great corner speed! Super Stable!

*ONE off setup for unique very high bite track.